



Installation Instructions Lock Box Accessory for the GearBoss® Shelving System

Basic Instructions only!
For more detailed product information, refer to the
GearBoss Shelving System Installation Instructions 241A298.

⚠ CAUTION
Make sure anyone assembling, installing or using this product has read and understands these instructions.

⚠ CAUTION
Failure to comply with Warnings and Cautions in this document or on the equipment can result in damage to property or serious injury.

⚠ CAUTION
Maximum load capacity rating for the lock box is 100 lb (45 kg).

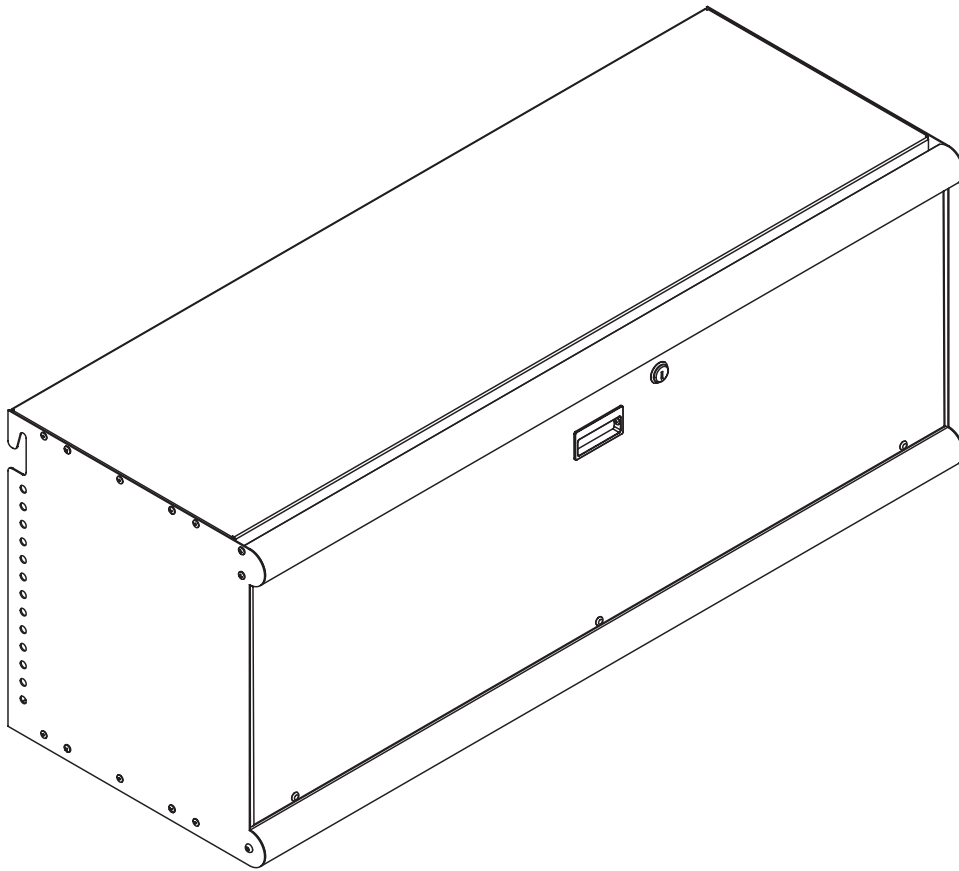

Contents

Installation 2 Replacement Parts 4



Visit the GearBoss Shelving System web page at gearboss.com for more information.

Note: Please read and understand these instructions before proceeding.
Note: If you need additional information, contact Wenger Corporation using the information below.

Installation

Installing the GearBoss Lock Box

1. Determine the location in which you would like the lock box located on the GearBoss shelving.
2. Insert the capscrew (10) through the upright tube (18) at the desired location on the GearBoss shelving.

NOTICE

Be sure the head of the capscrew is to the outside of the upright tube.

3. Secure capscrew (10) with the wing nut (1) leaving approximately 1/4" of threads between the upright tube (18) and the plastic wing nut (1).
4. Complete steps 1-3 on adjacent upright tube (18). Make sure the location of the second capscrew (10) is even with the first to ensure the lock box will be level.

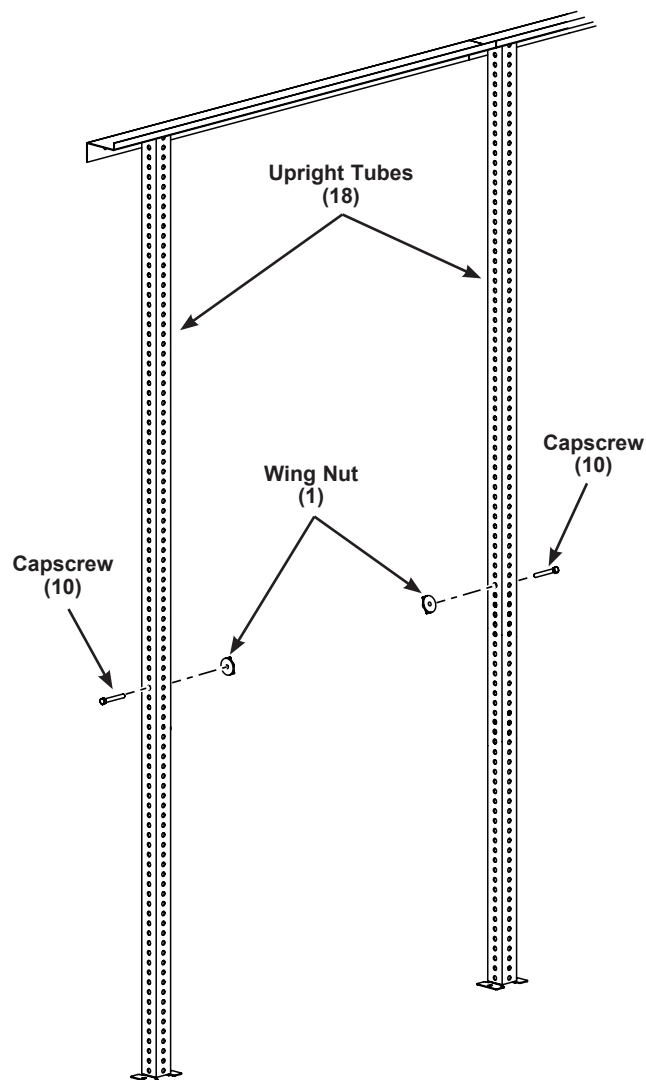

Lock Box Installation (continued)

5. Position the lock box to hook onto the capscrew (10) between the upright tube (18) and the wing nut (1).
6. Open the door of the lock box
7. Secure the lock box in place by tightening the wing nuts that are now on the inside of the lock box.
8. To secure the bottom of the lock box, insert the capscrew (10) through the upright tube (18) and bottom hole of the lock box. Again, make sure the head of the capscrew (10) is to the outside of the lock box.
9. Using the wing nut (1) on the inside of the lock box, secure the bottom in place.

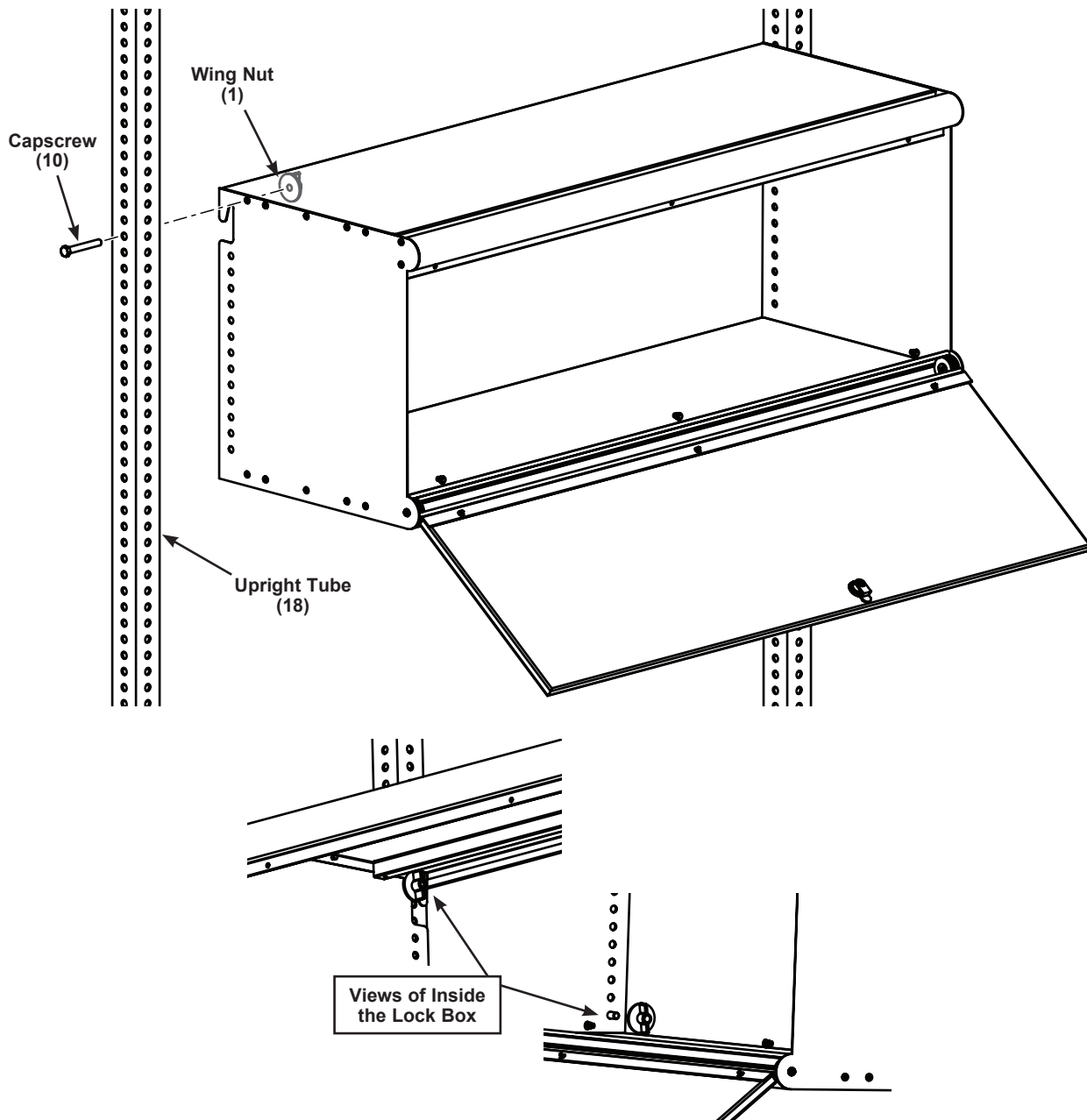

Replacement Parts

Item	Qty	Description	Item	Qty	Description
1	4	Wing Nut	10	4	3/8-16 x 2-3/4" Capscrew
2	2	Lock Box Side Plate	11	1	Lock
3	2	Lock Box Pan	12	4	Tube
4	2	Lock Box Extrusion	13	3	#8-32 x 1/2" Machine Screw
5	1	Lock Box Door Panel	14	12	Washer
6	3	#8-32 Insert Nut	15	1	Flush Mount Plastic Handle
7	12	3/16 Blind Rivets	16	2	1/4-20 Hex Socket Cap Nut
8	2	8-18 x 3/8" Screw	17	2	1/4-20 x 5/8" Machine Screw
9	12	#10-16 x 3/4" Screw	18	1	Lock Off-Set Cam

